



Noblelight® LightHammer® Mark III System Advanced Sensor Technology in Microwave-powered Lamp Heads

Further building upon our latest, most technologically advanced smart power supply platform, the LightHammer® Mark II, numerous sensors are now integrated into the Irradiator to make the Intelligent Irradiator. Noblelight's new Intelligent Irradiator is part of the **LightHammer® Mark III System**; making an industry first, complete Smart UV Curing System. The LightHammer® Mark III is IoT-enabled for today's and the future's Digitization Roadmap.

With intelligence now added to the Irradiator, the irradiator operating parameters can be measured and monitored remotely. The data obtained from the new sensors is sent to the associated LightHammer® Mark III power supply via a CAN communication. The entirety of this data can be viewed using the optional Noblelight monitoring software, Advanced Intelligent Monitoring System (AIMS®), now available for the LightHammer® Mark III Systems. This software application provides real-time system performance monitoring, enhanced system diagnostics, and preventative maintenance capability. Through the use of a proprietary communication network, many of the Smart UV Curing

System's critical performance metrics can now be measured and monitored by a PC connected to the unit's network.

Key Features

- New sensors added to measure relative UV intensity, irradiator air pressure, inlet air temperature, bulb temperature, magnetron temperatures, ambient temperature, air humidity, and irradiator orientation.
- System parameters can be monitored via the optional Advanced Intelligent Monitoring System (AIMS®).
- Provides accurate, real-time data to improve total cost of ownership, increase equipment and production up-times, increase operational intelligence, and improve system efficiency and reliability.
- Data can be used for system performance monitoring, system diagnostics and predictive maintenance, and much, much more.
- Intelligent Irradiator has same form and fit of existing LHI10 Mark II irradiators and can be a direct replacement for an existing Mark II irradiator.

Specifications: LH10 Mark III System

LHI10 Mark III Intelligent Irradiator

- Weight:** LHI10 Mark III: 19 kg (42 lbs.).
LHI10B Mark III: 28 kg (61 lbs.).
- Dimensions:** LHI10 Mark III: 267 mm (10.5 in.) long x 208 mm (8.2 in.) wide at base x 384 mm (15.13 in.) high;
LHI10B Mark III: 267 mm (10.5 in.)

long x 313 mm (12.32 in.) wide at blower top x 662 mm (26.07 in.) high.

- Cooling:** 7.7 m³/min. @ 2,500 Pa (270 scfm @ 10.0 in. H₂O) to 8.9 m³/min. @ 3,125 Pa (315 scfm @ 12.5 in. H₂O).

Mounting Position: Any orientation.

Operating Voltage: Powered through LHI10 Mark III power supply.

Substrate Location: 53 mm (2.1 in.) from face of lamp for maximum irradiance.

Footprint: 266.7 mm x 200 mm (10.5 in. x 7.87 in.).

Bulb Fills: D, H, H+, M, Q, and V.

Magnetron Output @100% Power: 240 W/cm (600 W/in.).

Sensors: Relative UV output, bulb temperature, analog air pressure, and others.

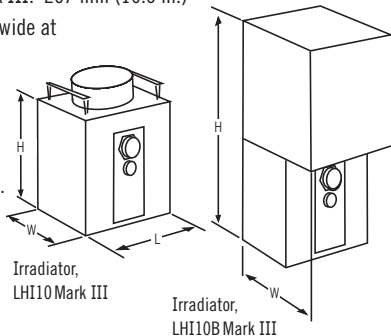

Intelligence Inside

- | | | |
|--|--|---|
| <ul style="list-style-type: none"> ■ UV Sensor ■ Bulb Temp Sensor ■ Mag A Temp Sensor ■ Mag B Temp Sensor ■ Inlet Air Temp Sensor | | <p style="text-align: center;">Main Board</p> <ul style="list-style-type: none"> ■ Orientation Sensor ■ Analog Pressure Sensor ■ Ambient Temp Sensor ■ Humidity Sensor |
|--|--|---|

LH Mark III Power Supply

- Improved/Lower Total Cost of Ownership
- Up to 20+% Energy Savings
- >99% Power Factor Correction
- ~90% High Efficiency
- Minimum Total Harmonic Distortion (THD)
- DC Output w/Essentially No Ripple
- Universal Industrial Input Power, Auto Ranging
- 4 Optional World Leading Industrial Open Communication Protocols
- IoT-Enabled
- Up to 75% Lighter than Ferro-Resonant PS
- Meets and Exceeds World-Wide Standards & Directives
- Backwards Compatible

Germany
Excelitas Noblelight GmbH
Reinhard-Heraeus-Ring 7
63801 Kleinostheim
Phone: +49 (6023) 405 9600
Fax: +49 (6181) 35 168410
hng-uv@excelitas.com
www.noblelight.com

USA
Excelitas Noblelight
America LLC
910 Clopper Road
Gaithersburg, Maryland
20878-1357
Phone: +1 301 527 2660
Fax: +1 301 527 2661
info.hna@excelitas.com
www.noblelight.com

Japan
Excelitas K.K.
Noblelight Division
Sumitomo Fudosan Otowa
Building 2F, 2-9-3
Otsuka, Bunkyo-ku
112-0012, Tokyo
Phone: +81 3 6902 6600
Fax: +81 3 6902 6613
info.hkk@excelitas.com
www.noblelight.com

China
Excelitas Noblelight (Shenyang) Ltd
No.108, Development 26th Road
Economic & Technological
Development Zone
Shenyang, Liaoning, 110027
China
Phone: +86 400 080 2255
Fax: +86 (0) 21 3357 5333
info.hns@excelitas.com
www.noblelight.com

LHP10 Mark III Power Supply

- Weight:** 25 kg (55 lbs.); 27 kg (60 lbs.) w/ blower control module.
- Dimensions (W x H x L):** 419 mm (16.5 in.) x 217 mm (8.54 in.) x 777 mm (30.6 in.) with connector.
- Cooling:** Internal fans.
- Input Voltages:** 200 V–480 V (auto-ranging), 3-phase, 50/60 Hz.
- Max Line Current:** At 380–480 V: 11.3–15 A, at 200–240 V: 23.5–28.6 A.
- Mounting Position:** Horizontal – unit can be free standing, stacked, or rack mounted.
- Line Power at 100%:** 10 kVA.
- Clearance:** Allow 305 mm (12 in.) clearance front and rear of the power supply for cooling air flow and cable connections.
- Safety Interlocks:** E-stop, external interlocks (customer I/O), RF fault.
- Mag Current @ 100% Power:** 890 mA/magnetron.
- Mag Current Output Accuracy:** ±1%.
- Power Factor @ 100% power:** 99%.
- I/O Communications:** ⁽¹⁾Master/Slave (dry contact)(S), DeviceNet™ (O), Profibus® (O), EtherNet/IP™ (O), Profinet® (O).
- Power Level Control:** 4–20 mA, 0–10 vdc, 4-bit binary, front panel.
- Front Panel Indicators/Controls:** Power On/Off switch, USB port, display unit with ON/Standby/OFF buttons and Power Level control buttons.

Specifications subject to change without notice.

⁽¹⁾LH10 Mark III Power Supply Power Level Control Options

Method	Control
4–20 mA input	1% steps, via master/slave operation
0–10 Vdc input	1% steps, via master/slave operation
4-bit binary input	5% steps, via master/slave operation
front panel switches	1% steps, via master/slave operation

Contact your local Excelitas Noblelight office for an engineered solution for your specific requirements.

ISO 9001 Certified QMS

